

No.: 0235 Hand-arm vibration: auxiliary handles with vibration attenuation

○ Problem

Hand-held machines, in particular angle grinders, usually feature auxiliary handles (side handles). Measurements in the field reveal that compared to the main handle, these handles cause higher exposure of the hand holding them to vibration.

Vibration-attenuating auxiliary handles can be retrofitted to machines by their users. A test method providing objective criteria for selection of the correct or most suitable handles does not exist at present.

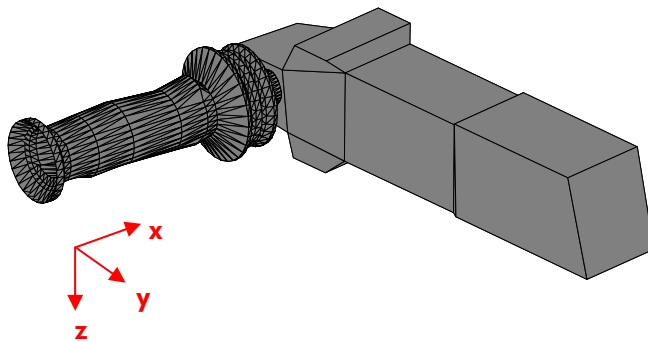

Figures: Schematic diagram showing the vibrating structure (left)
vibration-attenuated auxiliary handle on an angle grinder (right)

○ Activities

Systematic studies were conducted on handles both with and without vibration attenuation systems, and the natural oscillation behaviour of the various handle types studied by means of modal analysis.

For grinding machines, the vibration attenuation was measured with reference to the emission measurement standards on substitute work processes, and for the purpose of comparison also under actual working conditions.

The measurement standard was studied for its suitability for assessment of vibration-attenuating auxiliary handles, in particular with regard to the number and arrangement of the measurement points.

○ **Results and Application**

For dedicated vibration-attenuating handles supplied by the manufacturer for specific machines, the measurement points set out in the measurement standards are adequate. The measurement error is in the order of the currently attainable certainty of measurement. The use of other auxiliary vibration-attenuating handles, not recommended by the manufacturer, on angle grinders was also shown to influence the vibration behaviour of the appliance as a whole such that although vibrations on the auxiliary handle may be reduced, vibrations on the main handle may in fact be increased.

Guides are needed to assist users of machines in selecting handles from among those on the market. For this purpose, the standards are to include a test procedure which will be based upon the results of the study.

○ **Area of Application**

All sectors of commerce and industry; test bodies

○ **Additional Information**

- DIN V 45695: Hand-arm vibration – Guidelines for vibration hazards reduction – Engineering and management measures (04.96) (CEN-CR 1030-1:1995 and CEN-CR 1030-2:1995). Beuth, Berlin 1996
- Directive 2002/44/EC of the European Parliament on the minimum health and safety requirements regarding the exposure of workers to the risks arising from physical agents (vibration). OJEC L 177, 6 July 2002, pp. 13-20
- DIN EN ISO 20643: Mechanical vibration – Hand-held and hand-guided machinery – Principles for evaluation of vibration emission. Beuth, Berlin (currently at press)
 - ⇒ Expert assistance: BGI, Fachbereich 4: Arbeitsgestaltung – Physikalische Einwirkungen [BGI, Division 4: Ergonomics – Physical environmental factors]
 - ⇒ Literature requests: BGI, Zentralbereich [BGI, Central Division]

○ **“Focus on BGI's work”**

Published by:

Berufsgenossenschaftliches Institut für Arbeitsschutz – BGI
im Hauptverband der gewerblichen Berufsgenossenschaften – HVBG
53754 Sankt Augustin
Germany

Edited by: U. Kaulbars

Phone: +49 2241 231-02 / Fax: +49 2241 231-2234

e-mail: bgia@hvbg.de

Internet: www.hvbg.de/bgia